

40142 SIDE VIEW DIAGRAM

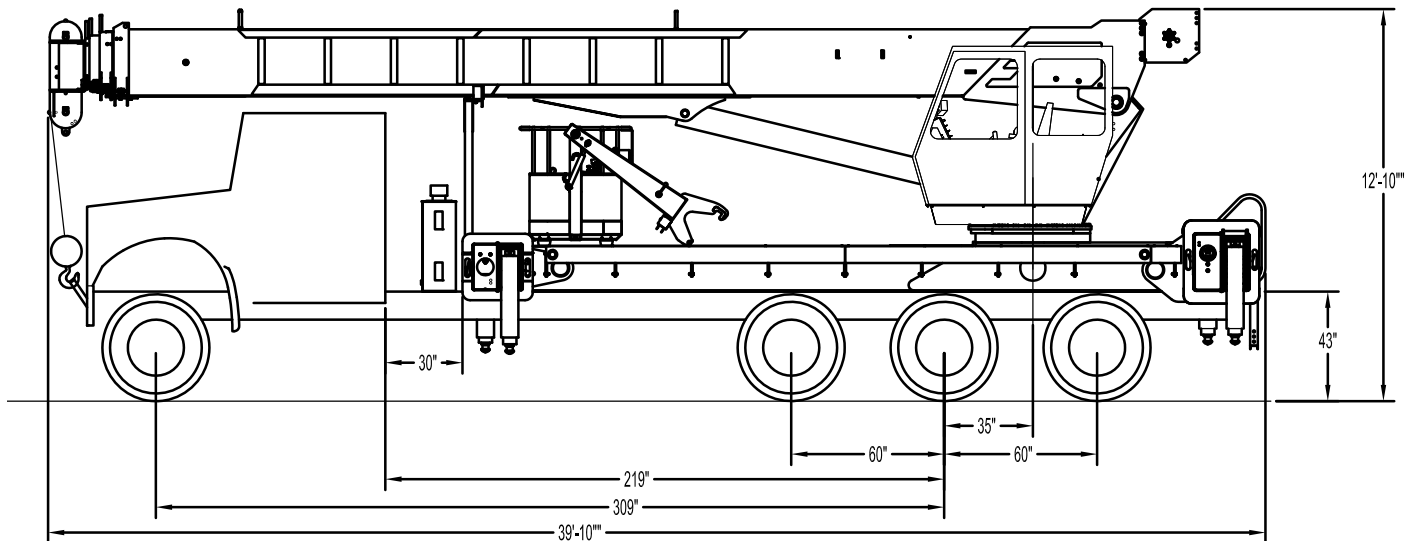

- | | | | |
|----------------------------------|-------------------------------|---------------------------------|--------------------------------|
| • Maximum Vertical Reach | 207'63,1 m | • Powered Boom Sections | 5 |
| • Working Area | 360 Degrees | • Overall Height | 12'10"/3,9 m |
| • Lifting Capacity | 80,000 lbs/36 287 kg | • Operator Controls | Rotating Cab with Control Seat |
| • Boom Length | 142'43,3 m | • Outrigger Type Front | Out-Down |
| • Crane Weight (Standard) | 40,300 lbs/18 280 kg | • Outrigger Spread Front | 21'2"/6,4 m |
| • Jib Lengths | 26', 31'-55'/ 8 m, 9,4-16,8 m | • Outrigger Type Rear | Out-Down |
| • Winch Bare Drum Pull | 15,000 lbs/6804 kg | • Outrigger Spread Rear | 26'2"/8 m |

TECHNICAL SPECIFICATIONS

Crane Capacity: 80,000 lbs at 7' load radius.

Maximum Tip Height: 142' height (207' with optional 32'-55' jib)

Control Console: Rotating seated controls with operator cab and deluxe operators seat. Station equipped with four pilot operated control levers for the main crane controls. Operator station includes LMI display, diesel heater, bubble level gauge, engine start/stop switch, signal horn button, variable speed throttle switch, lifting capacity chart, range diagram chart, boom angle indicator, system pressure gauge, 12V DC power source, and cup holder. Independent ground level electric operated outrigger controls.

Boom: Five-section fully proportional, high strength steel plated rectangular tube sections. 34'9" retracted and 142' extended boom. A maximum boom tip height of 152' mounted on a truck. The boom nose contains one floating upper sheave and three lower sheaves. Assembly includes heavy-duty cylinder fittings, pivot pins, and replaceable wear pads.

Winch: Mounted at the base of the boom for a long fleet angle and flat level spooling of cable. Winch is driven by a planetary reducer and powered by a hydraulic motor. Burst-of-speed winch provides increased line speed. The winch brake is spring applied, pressure release design. Supplied with 430' of 5/8" diameter rotation resistant wire rope with a single line pull of 11,300 lbs., and a downhaul ball with swivel hook for single part line.

Load Moment Indicator System: System senses hoist cylinder pressures, boom length and boom angle with hydraulic function lockout. The display console is equipped with a bar graph showing crane utilization, boom angle or boom length, a mode select controls for main boom and jib operation, and an anti-two block with an audio/visual

Elliott Equipment Company reserves the right to change the specification of any unit at any time without prior notice. This brochure is only a statement of general specifications on the date of this publication. For more detailed info on specific Elliott trucks go to www.elliottequip.com

warning and shut-off functions to limit hook-boom point contact. Internal boom anti-two-block.

Outriggers: Two sets of out and down overframe outriggers with 21'2" span in front and 26'2" span at rear. Outriggers are configured for full span or mid-span only. Outriggers equipped with 22" diameter ball socket aluminum removable pads that stow on vertical outrigger legs. Front bumper stabilizer may be required.

Frame: Full length, all welded rigid 4-plate design sub-frame. Sub-frame allows for bolt-on addition of aluminum bed wings, with top plate of subbase serving as a portion of the bed deck, to form a three-piece bed.

Turret: Reverse offset turret is one-piece weldment. Turret rotates on large diameter ball bearing.

Rotation: Hydraulic motor drives turret through double reduction planetary swing drive for 360 degree continuous rotation. Glide-swing drive system has manual foot applied brake

Lift: One double-acting long stroke cylinder provides smooth and stable boom elevation. Holding valve prevents boom from falling in event of hose failure.

Boom Extension: Incorporates a 2-stage hydraulic extension cylinder, attached to the largest boom section, with a proportional cable extension system driving the outermost sections.

Hoses: All high pressure hoses are wire braid reinforced with a minimum safety factor of 4 to 1.

Cylinders: All cylinders use microhoned cylinder tubing, chrome shafts, top grade packing and protective rod wipers. Cylinder-mounted holding valves provided on all load-holding cylinders.

Hydraulic System: Equipped with air-shift PTO, piston pump, SAE O-ring face seals on pressure lines, and a

10-micron return line filter. The control valve distributes all flow to hoist system, swing circuit, and other crane functions. System is closed center type. Includes hydraulic oil cooler.

Oil Tank Capacity: 143 gallon mounted to top of frame.

Cab Equipment: Air shift PTO with indicator lights installed in truck cab. U/L approved 5:BC dry chemical fire extinguisher installed in truck cab.

Operators Manual & Video: Two CD copies and one hard copy of operation, maintenance, safety and parts manual provided with each unit. Operational and safety video provided at delivery.

Installation: Unit installed on chassis, painted, system and tank filled with oil, tested, inspected, and ready to operate.

Standard Paint: Paint turret and boom white, outriggers red, and bed and boxes black.

Bumper: Bureau of Motor Carrier Safety rear bumper.

Weight: Approximately 40,300 lbs. with 18' aluminum bed less truck.

Truck Chassis Required: Approx. 219" C.T., RBM 3,300,000 in-lb. per rail, 20,000 lb. front axle and 78,000 lb. GVWR required. Trucks must have 12V electrical system with high capacity alternator, cab clearance stop/tail/backup lights, and I.D. lamps. Additional configurations available for bridge legal cranes and export. Contact factory when additional equipment is to be added.

Options:

Air Conditioning for Crane Cab.

32'-55' 2-Section Jib.

Gravity Leveled Work Platform.

Wireless Radio Remote Controls.

Auxiliary Winch Package.

Winch Drum Rotation Indicator.

Much More...

LOAD/RANGE CHART - MAIN BOOM, FULL-SPAN OUTRIGGERS



MODEL 4000

142-FT BOOM

MAIN BOOM LOAD RATINGS WITH FULLY EXTENDED OUTRIGGERS

LMI MODE: NONE

LOAD RATINGS IN LBS WITH OUTRIGGERS AND STABILIZERS FULLY EXTENDED																		
LOAD RADIUS IN FEET	LOADED BOOM ANGLE	34-ft	LOADED BOOM ANGLE	A	LOADED BOOM ANGLE	B	LOADED BOOM ANGLE	C	LOADED BOOM ANGLE	D	LOADED BOOM ANGLE	E	LOADED BOOM ANGLE	F	LOADED BOOM ANGLE	G	LOADED BOOM ANGLE	H
7	75.4	80,000																
8	73.2	75,000																
10	71.0	66,500	76.7	43,000														
12	67.3	56,100	74.3	43,000	79.1	43,000												
15	61.7	49,000	70.5	43,000	76.3	42,400	79.5	36,600										
20	50.9	35,500	63.6	34,000	71.4	34,000	75.7	31,700	78.7	24,900								
25	38.1	24,700	56.0	25,000	66.3	25,700	71.5	26,000	75.2	21,000	77.8	17,500						
30	19.3	18,300	47.8	18,800	60.6	19,250	67.2	19,300	71.7	18,400	75.0	16,000	77.5	13,400	79.3	11,500		
35			38.0	14,500	54.5	14,800	62.8	15,000	68.1	15,000	72.0	14,400	75.0	11,800	77.0	10,100	79.1	6,600
40			25.2	11,500	48.0	11,800	58.0	12,000	64.4	12,000	68.8	12,200	72.2	10,700	74.9	8,900	77.0	6,600
45					40.7	9,600	52.9	9,800	60.6	9,900	65.6	10,000	69.8	9,400	72.6	8,100	74.8	6,600
50					31.9	7,800	47.3	8,000	56.5	8,100	62.3	8,200	67.0	8,300	70.1	7,400	72.7	5,900
55					19.8	6,500	41.2	6,600	52.3	6,700	59.1	6,800	64.2	6,900	67.6	6,500	70.5	5,300
60						34.9	5,400	48.0	5,500	55.5	5,600	61.2	5,800	65.0	5,800	68.3	4,800	
65						26.4	4,400	43.0	4,500	51.8	4,700	58.1	4,700	62.4	4,800	65.9	4,300	
70						12.9	3,500	37.3	3,650	47.6	3,800	55.0	3,700	59.7	3,800	63.6	3,900	
75								30.8	2,900	43.1	3,000	54.6	3,000	56.9	3,100	61.2	3,200	
80								22.5	2,200	38.2	2,300	47.8	2,400	54.0	2,400	58.7	2,500	
85										32.7	1,750	43.8	1,850	50.8	2,000	56.2	2,000	
90										26.1	1,250	39.6	1,400	47.4	1,500	53.5	1,500	
95										17.1	800	34.9	1,000	43.8	1,100	50.7	1,100	
100												29.6	600	40.0	700	47.6	750	
105														35.8	500	44.3	500	
110																		
	0	16,000	0	9,550	0	5,600	0	3,300	0	1,650	0	500						
DEDUCTIONS FOR STORED EXT. JIB		950		700		550		450		400		350		300		250		200

NOTES:

1. Boom load ratings are based on loaded boom radius. Loaded boom angles are given as reference only. Increase boom angle if necessary to maintain load radius. Do not exceed maximum load radius.
2. Boom deflection is not illustrated.
3. Personnel handling and jib use are allowed only with full span outriggers.
4. Capacities do not exceed 85% stability. Do not exceed capacities recommended by ASME/ANSI B30.5.
5. Load ratings above the bold line are structurally limited.
6. Refer to manual for wind ratings.
7. Deductions must be made from rated loads for any loadline equipment or boom attachments such as hooks, load blocks, and stowed jibs. Weights of load handling devices such as slings and shackles shall be considered part of the load.

ELLIOTT EQUIPMENT CO. SUPPLIED
LOADLINE EQUIPMENT DEDUCTIONS:
OVERHAUL BALL.....210 LBS
ONE SHEAVE BLOCK.....470 LBS
TWO SHEAVE BLOCK.....592 LBS
THREE SHEAVE BLOCK.....639 LBS
FOUR SHEAVE BLOCK.....762 LBS
AUXILIARY SHEAVE.....100 LBS

NOTE:
SEE PAGE 2 FOR A TABLE OF ROPE LIMITS AND A REEVING DIAGRAM FOR MULTIPLE PARTS OF LINE.

RANGE DIAGRAM WITH FULL SPAN OUTRIGGERS

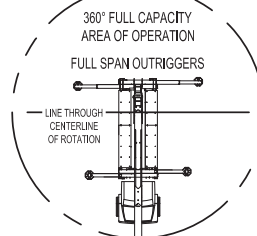
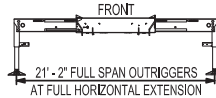
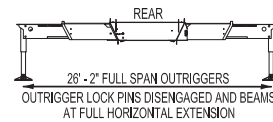
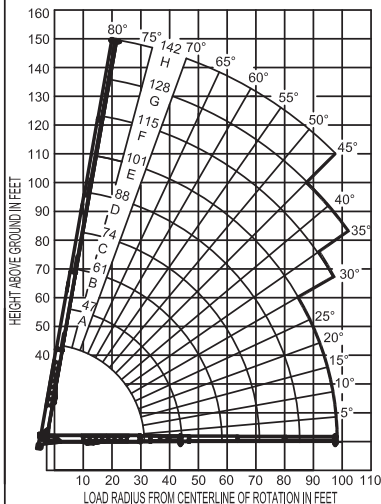

LMI OPERATING MODES

LMI MODE	CRANE CONFIGURATION	PAGE
NONE	LOADLINE LIFTING (FULL SPAN OUTRIGGERS)	1
NONE	LOADLINE LIFTING (MID SPAN OUTRIGGERS)	2
PLTF600MB	PLATFORM ON MAIN BOOM (600 LB LOAD)	3
PLTF1200MB	PLATFORM ON MAIN BOOM (1200 LB LOAD)	3
31' JIB RET	LOADLINE LIFTING WITH RETRACTED JIB	4
55' JIB EXT	LOADLINE LIFTING WITH EXTENDED JIB	4
PLTF600_31	PLATFORM ON RETRACTED JIB (600 LB LOAD)	5
PLTF600_55	PLATFORM ON EXTENDED JIB (600 LB LOAD)	5
PLTF1200_31	PLATFORM ON RETRACTED JIB (1200 LB LOAD)	6
PLTF1200_55	PLATFORM ON EXTENDED JIB (1200 LB LOAD)	6

CRANE MEETS ASME B30.5 REQUIREMENTS AT TIME OF MANUFACTURE

1206290 040115

LOAD/RANGE CHART - MAIN BOOM, MID-SPAN OUTRIGGERS



MODEL 4000 142-FT BOOM

MAIN BOOM LOAD RATINGS WITH MID-SPAN OUTRIGGERS

LMI MODE: NONE

LOAD RADIUS IN FEET	LOADED BOOM ANGLE	LOAD RATINGS IN LBS WITH OUTRIGGERS AND STABILIZERS EXTENDED																
		34-ft	A 47-ft	B 61-ft	C 74-ft	D 88-ft	E 101-ft	F 115-ft	G 128-ft	H 142-ft								
7	75.4	80,000																
8	73.2	75,000																
10	71.0	66,500	76.7	43,000														
12	67.3	56,100	74.3	43,000	79.1	43,000												
15	61.7	49,000	70.5	43,000	76.3	42,400	79.5	36,600										
20	50.9	33,000	63.6	34,000	71.4	34,000	75.7	31,700	78.7	24,900								
25	38.1	17,000	56.0	17,500	66.3	17,900	71.5	24,000	75.2	21,000	77.8	17,500						
30	19.3	11,800	47.8	12,300	60.6	12,700	67.2	13,000	71.7	13,100	75.0	16,000	77.5	13,400	79.3	11,500		
35			38.0	8,800	54.5	9,200	62.8	9,300	68.1	9,500	72.0	9,800	75.0	11,800	77.0	10,100	79.1	6,600
40			25.2	6,500	48.0	6,600	58.0	6,800	64.4	6,900	68.8	7,100	72.2	8,900	74.9	8,900	77.0	6,600
45					40.7	5,000	52.9	5,400	60.6	5,500	65.6	5,700	69.8	5,900	72.6	5,900	74.8	5,900
50					31.9	3,800	47.3	4,200	56.5	4,400	62.3	4,600	67.0	4,700	70.1	4,700	72.7	4,700
55					19.8	2,800	41.2	3,200	52.3	3,300	59.1	3,500	64.2	3,600	67.6	3,600	70.5	3,600
60							34.9	2,400	48.0	2,500	55.5	2,600	61.2	2,700	65.0	2,700	68.3	2,700
65							26.4	1,700	43.0	1,800	51.8	1,900	58.1	2,000	62.4	2,000	65.9	2,000
70							12.9	1,100	37.3	1,200	47.6	1,300	55.0	1,400	59.7	1,400	63.6	1,400
75									30.8	800	43.1	900	54.6	1,000	56.9	1,000	61.2	1,000
80														54.0	700	58.7	700	
85																		
0		10,000	0	4,800	0	2,000	0	600										
DEDUCTIONS FOR STOWED EXT. JIB		950	700	550	450	400	350	300	250	200								

- NOTES:**
1. Boom load ratings are based on loaded boom radius. Loaded boom angles are given as reference only. Increase boom angle if necessary to maintain load radius. Do not exceed maximum load radius.
 2. Boom deflection is not illustrated.
 3. Personnel handling and jib use are allowed only with full span outriggers.
 4. Capacities do not exceed 85% stability. Do not exceed capacities recommended by ASME/ANSI B30.5.
 5. Load ratings above the bold line are structurally limited.
 6. Refer to manual for wind ratings.
 7. Deductions must be made from rated loads for any loadline equipment or boom attachments such as hooks, load blocks, and stowed jibs. Weights of load handling devices such as slings and shackles shall be considered part of the load.

ELLIOTT EQUIPMENT CO. SUPPLIED LOADLINE EQUIPMENT DEDUCTIONS:

- OVERHAUL BALL.....210 LBS
- ONE SHEAVE BLOCK.....470 LBS
- TWO SHEAVE BLOCK.....592 LBS
- THREE SHEAVE BLOCK.....639 LBS
- FOUR SHEAVE BLOCK.....782 LBS
- AUXILIARY SHEAVE.....100 LBS

RANGE DIAGRAM WITH MID-SPAN OUTRIGGERS

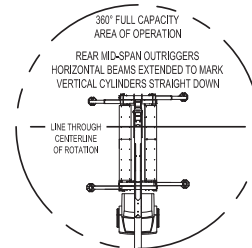
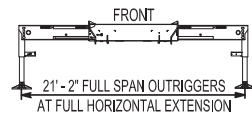
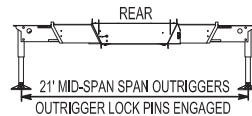
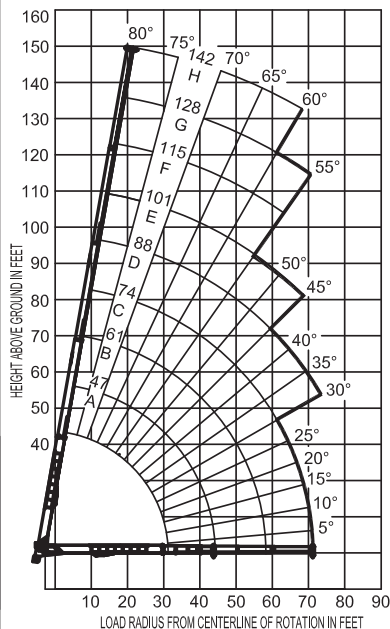

PARTS OF LINE

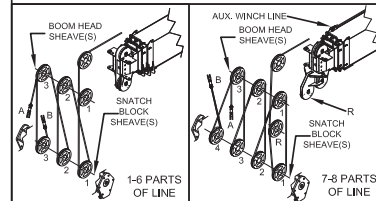

PARTS OF LINE	SHEAVES ON BOOM HEAD	SHEAVES ON SNATCH BLOCK	5/8" - SPIN RESISTANT 56,500-lbs. BREAKING STRENGTH (6:1 S.F.)	5/8" - 6X36 IWRC 45,400-lbs. BREAKING STRENGTH (3.5:1 S.F.)
1	1	A	11,300 lbs	12,500 lbs
2	1 B	1	22,600 lbs	25,000 lbs
3	1 2	1 A	33,900 lbs	37,500 lbs
4	1 2 B	1 2	45,200 lbs	50,000 lbs
5	1 2 3	1 2 A	56,500 lbs	62,500 lbs
6	1 2 3 B	1 2 3	67,800 lbs	75,000 lbs
7	R 1 2 3	1 2 3 A	79,100 lbs	80,000 lbs
8	R 1 2 3 B	1 2 3 A	80,000 lbs	-

A - DEAD END FOR ODD PARTS OF LINE B - DEAD END FOR EVEN PARTS OF LINE
R - ROOSTER SHEAVE REQUIRED WHEN USING 7-8 PARTS OF LINE

- NOTICE:**
- DO NOT DEADEND LINE BLOCK AGAINST BOOM TIP WHEN EXTENDING BOOM.
 - KEEP AT LEAST 5 WRAPS OF LOADLINE ON THE WINCH DRUM AT ALL TIMES.
 - USE ONLY 5/8" DIAMETER ROPE, AS SPECIFIED, WITH THE PROPER BREAKING STRENGTH LISTED.
 - ANTI-TWO-BLOCK SYSTEM MUST BE IN GOOD OPERATING CONDITION BEFORE OPERATING CRANE. SEE OPERATION & SAFETY MANUAL.

CRANE MEETS ASME B30.5 REQUIREMENTS AT TIME OF MANUFACTURE

1206290 040115



Elliott Equipment Company Phone: 402-592-4500
4427 South 76th Circle Fax: 402-592-4553
Omaha, NE 68127 Email: sales@elliottequip.com

Built for You.
www.elliottequip.com

LOAD/RANGE CHART - 2-SECTION JIB, FULL SPAN OUTRIGGERS



MODEL 4000

142-FT BOOM

JIB RANGE DIAGRAM WITH FULLY EXTENDED OUTRIGGERS

LMI MODES: 31' JIBRET & 55' JIBEXT

31' - 55' TWO SECTION JIB

31' RETRACTED JIB - LMI MODE: 31' JIBRET



55' EXTENDED JIB - LMI MODE: 55' JIBEXT



LMI MODE: 31' JIBRET		
LOAD RADIUS (FT)	LOADED BOOM ANGLE	LOAD RATING (LBS)
33	80	3,600
50	75	3,600
65	70	1,200

LMI MODE: 55' JIBEXT		
LOAD RADIUS (FT)	LOADED BOOM ANGLE	LOAD RATING (LBS)
40	80	2,400
56	75	2,400
76	70	800

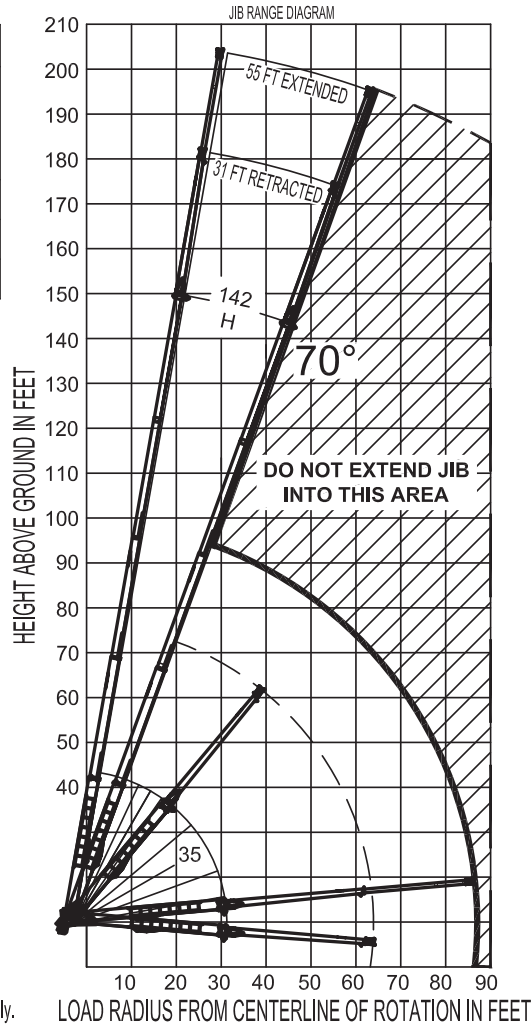

USE OUTRIGGERS AT ALL TIMES

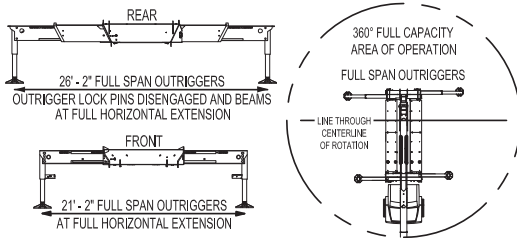

NOTES:

1. Operate jib by radius when main boom is extended. Increase boom angle if necessary to maintain load radius. Do not exceed the maximum load radius.
2. When the main boom is retracted, operate jib by boom angles. Do not exceed any rated jib capacities at reduced boom lengths.
3. Material handling with the jib is allowed only with full span outriggers.
4. Material handling with the jib is allowed only at boom angles above 70°.
5. Boom deflection is not illustrated. Loaded boom angles are shown for reference only.
6. Refer to manual for wind ratings.

CRANE MEETS ASME B30.5 REQUIREMENTS AT TIME OF MANUFACTURE

1206290 040115

RANGE CHART - MAIN BOOM, PLATFORM ATTACHED



MODEL 4000

142-FT BOOM

MAIN BOOM LOAD RATINGS WITH PLATFORM ATTACHED

LMI MODES: PLTF600MB & PLTF1200MB

PLATFORM LOAD	MAXIMUM RADIUS
1200 LBS	70 FT
600 LBS	80 FT

MAXIMUM PLATFORM CAPACITY RATINGS:
 1200 LBS
 2 PERSONS

USE OUTRIGGERS AT ALL TIMES

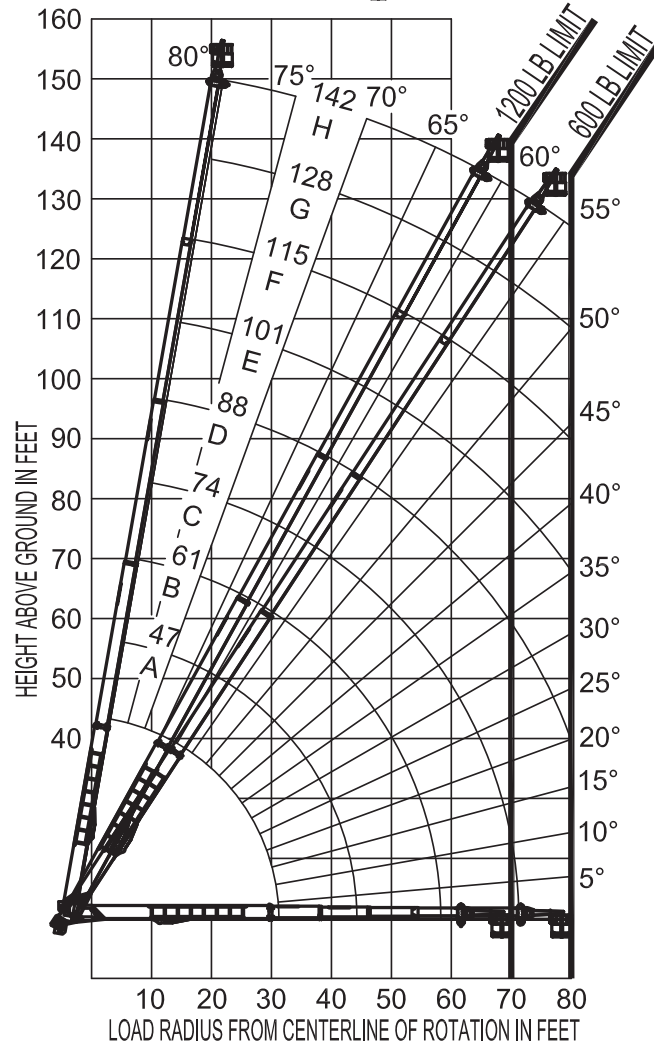
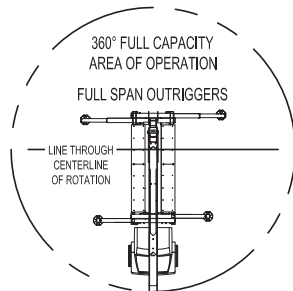
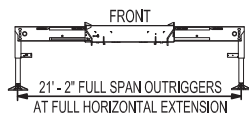
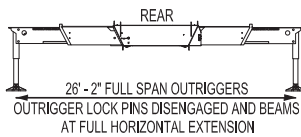

NOTES:

1. Personnel handling is allowed only with full span outriggers.
2. Loaded boom angles are given as reference only.
3. Boom deflection is not illustrated. Increase boom angle if necessary to maintain load radius. Do not exceed the maximum load radius.
4. Refer to manual for wind ratings.

CRANE MEETS ASME B30.5 REQUIREMENTS AT TIME OF MANUFACTURE

1206290 040115

RANGE CHART - TWO-SECTION JIB, PLATFORM ATTACHED (600 LB RATING)

ELLIOTT
EQUIPMENT COMPANY

MODEL 4000

142-FT BOOM

2 PIECE JIB RANGE DIAGRAM WITH PLATFORM ATTACHED - 600 LB

LMI MODES: PLTF600_31 & PLTF600_55

600 LBS MAX PLATFORM LOAD

65° MIN ELEVATED BOOM ANGLE

USE OUTRIGGERS AT ALL TIMES

LMI MODE	MAX ELEVATED RADIUS
PLTF600_31	74 FEET
PLTF600_55	84 FEET

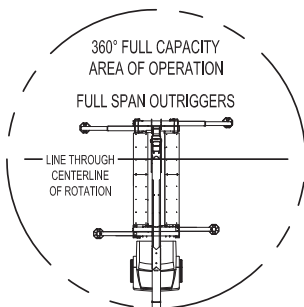
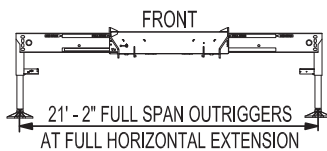
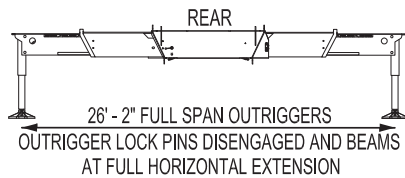

NOTES:

1. Operate jib and platform by radius when main boom is extended. Increase boom angle if necessary to maintain load radius. Do not exceed the maximum load radius.
2. When the main boom is retracted, operate jib and platform by boom angles. Do not exceed any rated jib and platform capacities at reduced boom lengths.
3. Personnel handling is allowed only with full span outriggers.
4. When handling personnel, actual load radius is measured to the far railing of the platform. Actual load radius can be up to 4 ft beyond the radius indicated by the LMI due to the platform offset. The LMI indicates radius to the load line for all jib modes.
5. Boom deflection is not illustrated. Loaded boom angles are shown for reference only.
6. Refer to manual for wind ratings.

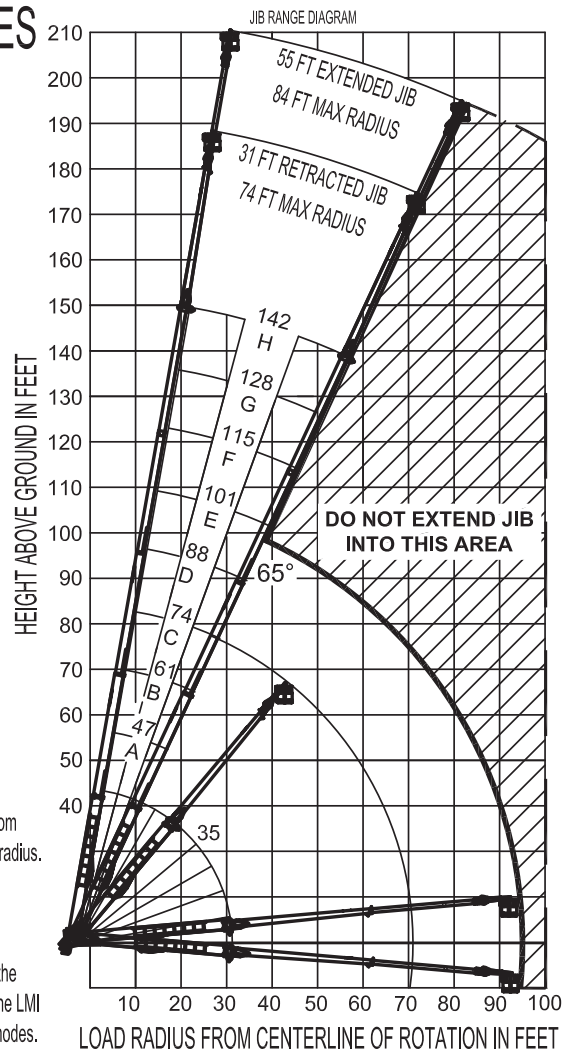

CRANE MEETS ASME B30.5 REQUIREMENTS AT TIME OF MANUFACTURE

1206290 040115

RANGE CHART - TWO-SECTION JIB, PLATFORM ATTACHED (1,200 LB RATING)



MODEL 4000

142-FT BOOM

2 PIECE JIB RANGE DIAGRAM WITH PLATFORM ATTACHED - 1200 LB LMI MODES: PLTF1200_31 & PLTF1200_55

1200 LBS MAX PLATFORM LOAD

65° MIN ELEVATED BOOM ANGLE

USE OUTRIGGERS AT ALL TIMES

LMI MODE	MAX ELEVATED RADIUS
PLTF1200_31	70 FEET
PLTF1200_55	79 FEET

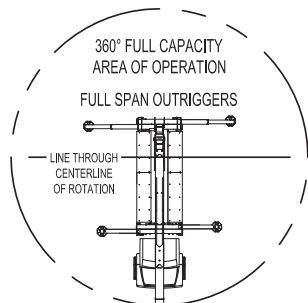
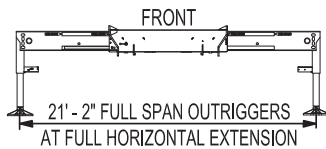
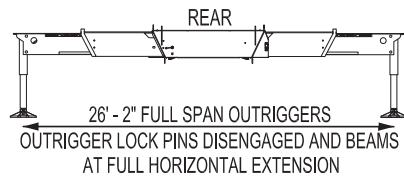

NOTES:

1. Operate jib and platform by radius when main boom is extended. Increase boom angle if necessary to maintain load radius. Do not exceed the maximum load radius.
2. When the main boom is retracted, operate jib and platform by boom angles. Do not exceed any rated jib and platform capacities at reduced boom lengths.
3. Personnel handling is allowed only with full span outriggers.
4. When handling personnel, actual load radius is measured to the far railing of the platform. Actual load radius can be up to 4 ft beyond the radius indicated by the LMI due to the platform offset. The LMI indicates radius to the load line for all jib modes.
5. Boom deflection is not illustrated. Loaded boom angles are shown for reference only.
6. Main boom extension is limited to 132 ft when the platform load exceeds 600 lbs.
7. Refer to manual for wind ratings.

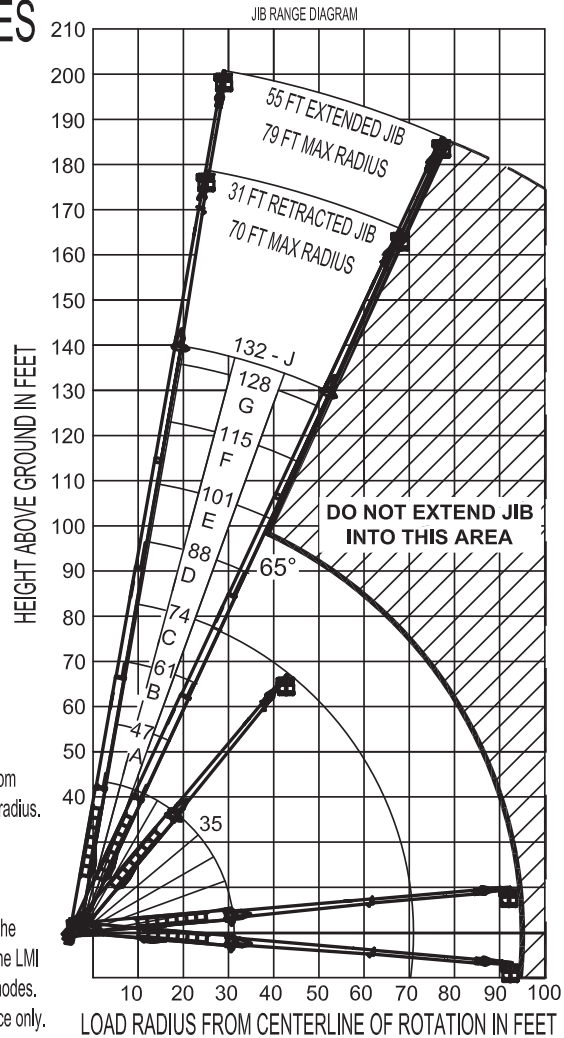

CRANE MEETS ASME B30.5 REQUIREMENTS AT TIME OF MANUFACTURE

1206290 040115

TRUCK CHASSIS SPECIFICATIONS

	40142 BoomTruck
Wheelbase (WB)	309" / 785 cm
Cab to Axle (CA/CT)	219" / 556 cm
Cab to End of Frame (EOF)	Contact Factory
Frame Section Modulus	30.0 in3-110,000 psi / 758 428 kPa
Front Axle Gross Weight Rating	20,000 lb / 9072 kg
Rear Axle Gross Weight Rating	58,000 lb / 26 308 kg
Permit-Free Truck Configurations	Contact Factory for More Information

Chassis data is minimum general requirements-not for engineering.
 Actual dimensions and truck data will depend on truck selection and axle configuration.
 *Minimum chassis weight is required to meet 85% stability requirements.

OPTIONS



Radio Remote Control

Interference protected radio remotes let you get closer to your work and have full control over your machine. Optional LMI display is available.

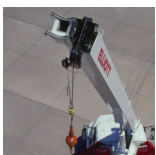

Pin-On Jib Attachments

One piece & two piece telescoping or fixed jibs that stow on the side of the boom for easy setup while on the jobsite.



Air Conditioning in Crane Cab

Work all day in comfort with an high efficiency air conditioning system mounted on the rear of the crane control cab.



Dual Winch System & Drum Indicators

Take advantage of Elliott's auxiliary dual winch package with optional drum rotation indicators.



Tool Boxes

Optional tool boxes and bed storage can accommodate any storage need for tools, work materials and more.

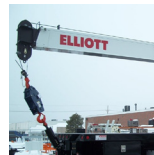

Hook Block for Multi-Part Line

Elliott can include a hook block device for up to 8 parts of line to improve lifting capabilities and allow you to maximize your use of the crane.



2-Man Yoke Work Platform

Elliott's new 2-man platform features hydraulic yoke lifting system for easy attachment to the boom tip. Fully OSHA compliant and heavy duty.



Body Mounted Hose Reels and Circuits

Let us work with you to customize your tool compatability by adding hose reels or hydraulic circuits to the crane bed.